



Welcome:

Thank you for looking into the U-Drain floor drain system. This paper will explore the functional features of the U-Drain and why it is superior to other grated systems in the marketplace. We will also cover the design considerations and installation requirements of the U-Drain floor drain system.

What is U-Drain?

U-Drain is a single-slot NON-grated pre-engineered floor drain. U-drain is available in a commercial and residential format in, both, stainless or galvanized steel. U-Drain is the most cost effective, low maintenance drain system on today's market. This system is used to remove water with a complex grading or other water channeling device. The commercial U-Drain is constructed with a slot opening of 1" and the residential U-drain is constructed with a ½" slot opening. U-drain does not have grating over the top and requires far less maintenance than other styles of pre-engineered trench drains, including drain systems with self-cleaning functions. The absence of grating helps make this single-slot, open floor/surface drain durable, sanitary and cost effective.

Drain Materials

The U-Drain comes standard with a *galvanized* finish; it is available in stainless steel when sanitary issues are a concern. Strong and lightweight, stainless steel and galvanized metal U-drain come in 3 meter (9'10") sections that are pre-sloped .05% (1/2") per section. Absorption rates can vary, however, the U-Drain stainless steel channels are ideal for the food and beverage industry where traditional trench drain grating may trap bacteria.

Flow

Each 10' Section of U-Drain has 120 Square inches of intake. This means that the flow rate is determined by which sections of U-Drain are installed and what sump discharge options fit the end user best. With the proper components, flow rates of over 1000GPM are attainable.

Residential U-Drain sections, which come in 5' lengths, have 30 Square inches of intake and have a maximum capacity of 240 GPM.

Functions & Features

Commercial Applications

The commercial-grade U-Drain system is available in 16-gauge, hot dipped galvanized or stainless steel, in three meter (3m = 9' 10") sections that are pre-sloped .05% ($\frac{1}{2}$ "). Un-sloped 5', 3', and 1' sections are used for extending along short distances. The system begins with an "end" section (one with a sealed end) which slopes towards a sump pit (collector pit). Sloped sections are inserted to lengthen the drain to the required length. Each section has a coupling flange welded to it that is alphabetically coded to the depth of that end of section, i.e. a "B-C" section would start with a "B" flange, and over the course of the section it drops $\frac{1}{2}$ " and ends with a "C" flange. The next connecting piece would start with a "C" flange and slope towards a "D" flange at the other end. The flanges are bolted together in a four-bolt pattern. Starting with the end capped section (EA = End - A), 120' of continuous one-way Slope is available. If the application is longer than 120', supplementary neutral 3-meter sections are fitted in to lengthen the drain (these sections will have the same end flanges, i.e. "C-C").

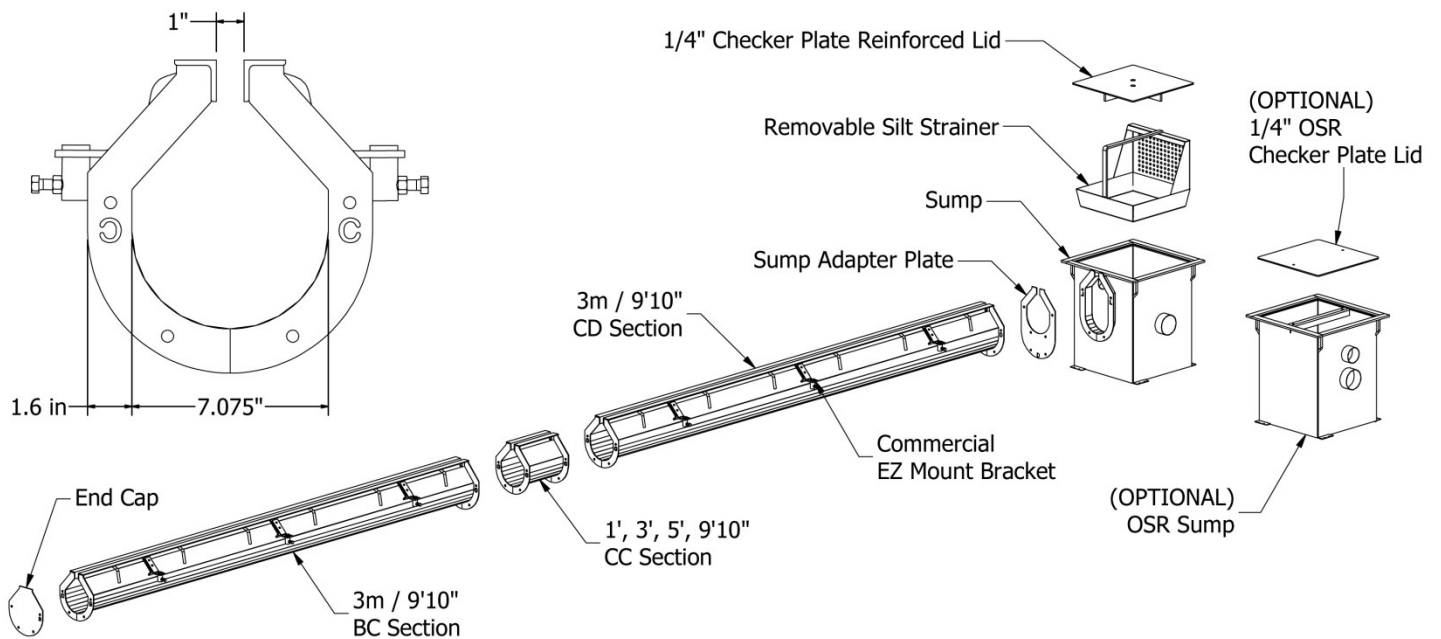

Structural Capabilities

The structural capabilities of the drain system are in direct relation to the strength of the concrete the U-Drain is engineered in such a way that, through the breaks in the walls of the drain, the weight load is channeled through the U-Drain and into the concrete floor. This is provided that the U-Drain is properly secured into the rebar grid, and the proper amount of concrete is around and under the U-Drain. The structural capabilities of U-Drain system make it especially suited for heavy, high traffic applications, such as airports, parkades, warehouses, and truck and rail loading docks. The system is also structurally sound enough to support not only crossing traffic, but lateral crossings as well. Direct loads parked on top of the drain will not “crush in” the U-Drain because it is supported by the surrounding concrete.

In addition, because the structural capabilities are the same as the strength of the encasing concrete, consideration of machinery placement is not limited by the placement of the U-Drain system

Aesthetics

The U-Drain system is aesthetically pleasing to the eye because there is only one straight channel in the floor, slightly wider than a floor expansion joint. The single slot profile blends in neatly with surface materials while providing an effective solution to surface water drainage. The drain system’s clean, crisp lines are suitable for a wide variety of residential and commercial applications.

Cleaning

The U-Drain becomes a self-cleaning drainage system because of its pre-engineered slope. However, it can be cleaned out manually in a variety of ways. A drain cleaning paddle, which is sold separately, is shaped to fit the bottom of the slot drain. To restore proper water flow, the paddle is inserted sideways into the slot and given a 90° turn before being dragged along the drain to remove any dirt and debris. Another common way to clean out a U-Drain system is to attach a custom flush valve (½” standard) to the closed end of the system. The flush valve may be set to turn on automatically with timers or turned on manually in order to flush the system and remove any sediment or contaminants. A pressure washer may also be used to clean out the system. Simply slide the nozzle in one end and run it the length of the drain. A stainless steel U-Drain system is durable and sanitary, making it an ideal system for the food and beverage industry or facilities with stringent sanitary regulations. The only parts of the drain exposed are the surface angles, which are made of stainless steel, making it easy to scrub down and sanitize. Since there is no grating, there are no components to break, bend, or trap bacteria.

Commercial System Features

Rebar tie-ins

Alongside the trench, every 24", an 8" rebar section is welded, bent out 3" from the side of the trench. This allows for a proper tie into the rebar grid in the concrete, as well as a place to tie the heat pipe.

Leveling brackets

Leveling bracket mounts are welded into place, and leveling brackets are bolted onto the side of the trench to ensure proper leveling of the drain. A rebar length is pounded into the ground through a slot in the bracket. Once the rebar is firm and below the top of pour, the bracket's set screw is ready for tightening. This system allows for quick placement and leveling done with minimal manpower. These brackets support either 10mm or 15mm (3/8" to 1/2") rebar.

Sump pits

A U-Drain system bolts directly to a sump pit. The pits are available in a variety of designs. The volume of liquid being moved is the most important factor to consider when selecting a sump pit design. A deep, single inlet sump (i.e. 18" x 18" x 24"), may have a checker-plated lid, as well as a silt basket. The silt basket, also made of galvanized or stainless steel, is used for quick removal of debris, as well as acting as a screen to the out-take line. A single inlet style of sump connects one line of the U-Drain and contains a drain exit pipe. A 120' continuous flow drain can be connected to a single inlet sump, and by inserting a three-meter neutral section, it can be extended to 150'. Sump pits are fitted with an "L" flange mounted on the intake, and an adaptor plate is bolted to the corresponding mounting end of the drain section. The adaptor plate has the outside diameter of the "L" flange and the corresponding inside diameter of the end of the drain section. All flanges are laser cut for easy matching and assembly. Sumps may be available as dual inlet standard formats as well. A dual inlet can support up to 300' of drain. This length allows for simplified concrete pours, creating the need for only a two-slope pour

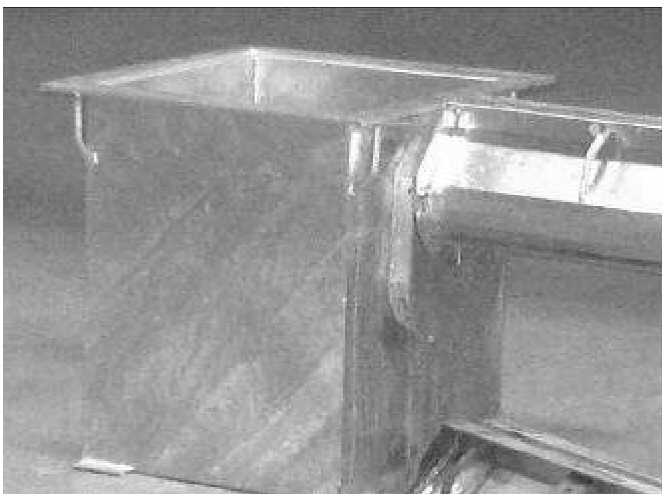

Oil separator pits

Many sump sizes are available with oil separation catch pits. In these configurations, the pit attached to the U-Drain contains the solids and the oil. A secondary pit is the overflow, where mostly clean water collects and is then discharged to sanitary/sewer pipes. It works like a skimmer: oil floats to the top and water flows through the elbow which is in the initial sump pit.

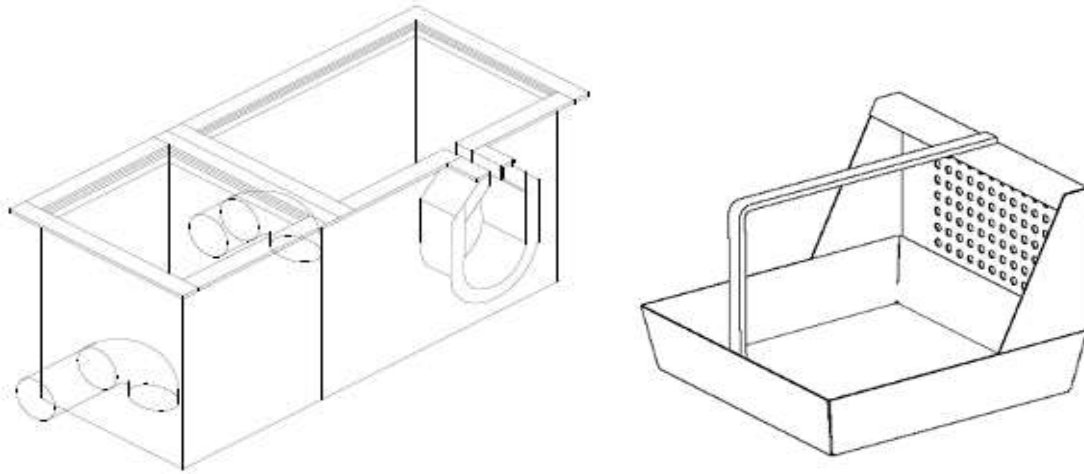

Sump lids

Checker-plated lids (shown right) are used in the vast majority of applications since they are strong enough to support road vehicles and forklifts. For applications that require more substantial load-bearing abilities, a grated sump pit lid (shown left) cover is recommended. Grated sump pit lid covers are often used in heavy machine shops or in high flow situations such as car washes or in storm drain applications. The checker-plated lids are lighter, and by that virtue, a less expensive alternative.

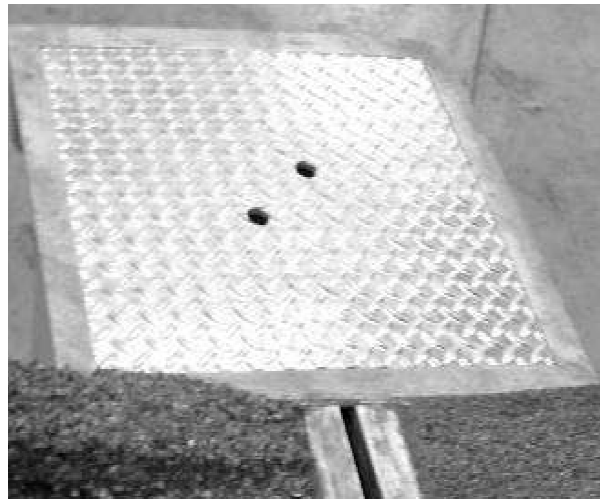

Sump pit alternatives

Not all applications require that a sump pit be placed at the end of the drain line. By custom fitting, an end cap direct flow pipe can be placed to drain liquid directly from the slot drain into a pipe drain. End caps are available for all flange types with 4.5" OD stubs for easy tie into ABS lines with furnco fittings.

Residential Applications

Sharing the same features of a commercial drain system, U-drain systems are also available for residential applications. The standard 60" (5') lengths of a residential system are not pre-sloped, and shorter sections may be available upon request. This drain system renders the four-slope floor obsolete. Two simple slopes to the U-Drain is all that is required. The residential system comes with a standard, ADA compliant, 1/2" slot opening which can handle anything from snow melt to washing a car indoors. As seen in the diagram on the previous slide, a 12" x 12" x 12" sump pit with a checker-plated lid is used in a residential application; however, larger sizes are available. Consult individual manufacturers. Sumps may also be available in single or dual inlet formats, and in many residential situations, the U-Drain is run directly through a PVC pipe directly to sanitary/sewer lines or directed outside to natural drainage.

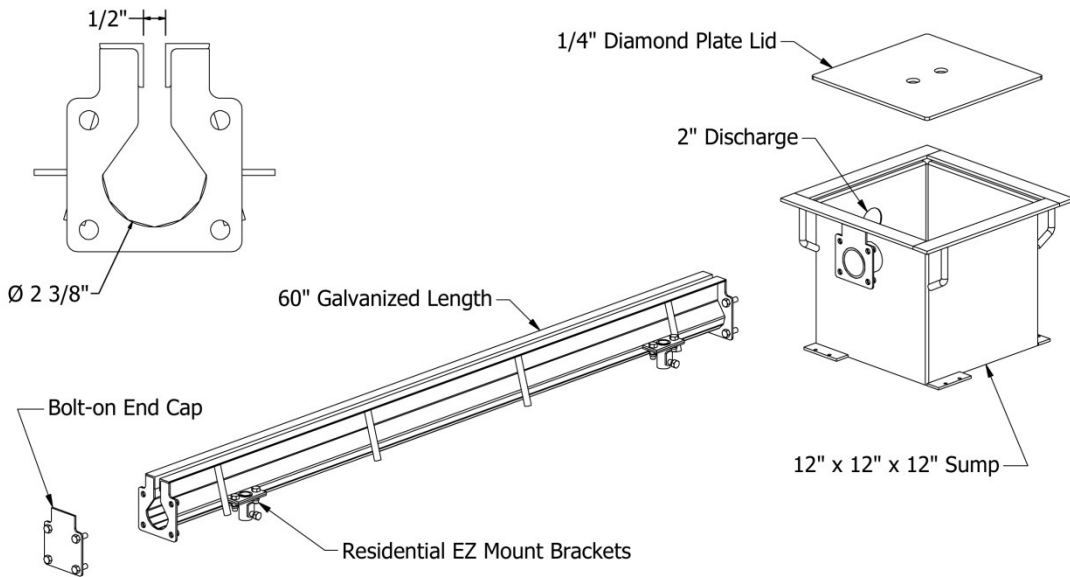

Installation

U-Drain systems arrive at the site in sections, factory-ready for bolting together. A simple 8-step process will have you set and ready for use in a fraction of the time of a traditional grated drain system.

Step 1

Excavate a trench allowing room underneath and on both sides of the U-Drain. There should be a minimum of 6" of concrete surrounding the drain.

Step 2

It is recommended to pre-pour a concrete pad underneath the sump pit so it can be properly secured. If no pad is poured, peg the sump pit down (using rebar mounting brackets welded to the sides of the sump) before the U-Drain is connected.

Step 3

Install all sump pits and PVC piping, making sure that the sump pit walls are reinforced to prevent sidewall bowing.

Step 4

Bolt the last, deepest, Section of the U-Drain to the sump pit. If a sump pit is not being used, secure the deepest section against the forming. Bolt all remaining sections of the U-Drain together using the lettered flanges as a guide. For example, section "End-A" bolts to "A-B" and "A-B" bolts to "B-C", etc.

Step 5

Fasten the mounting brackets at marked intervals along the drain using the hardware supplied by the manufacturer. With the rebar running through the conduit portion of the mounting brackets, pound the appropriate length of rebar into the base material. When the correct levels are achieved, tighten the set bolts on the mounting brackets to secure the drain into place. Securing in the U-Drain through the base allows a contractor the ability to use the top as a screed edge to perfect the slope of the concrete.

Step 6

Once the U-drain is secured to the mounting brackets and the appropriate floor height is found, for structural support, tie the rebar from the floor grid into the rebar on the drain assembly. Cover the opening with duct tape, or insert Styrofoam if needed.

Step 7

To ensure that the U-Drain will not float, it is recommended that the concrete be poured in two stages. The first concrete pour should adhere to a manufacturer's warning stickers on the side of the drain assembly. Once adequate time for the first concrete pour to set has elapsed, the floor slab can be completed. The use of a pencil vibrator is strongly recommended to make sure that the concrete has completely surrounded the U-drain, leaving no bubbles or voids.

Step 8

Once the concrete slab is firm, first remove the tape or Styrofoam from the slot then break out all metal tabs with a steel bar to ensure a continuous open slot. Using the paddle, clean out the U-drain and sump pit.

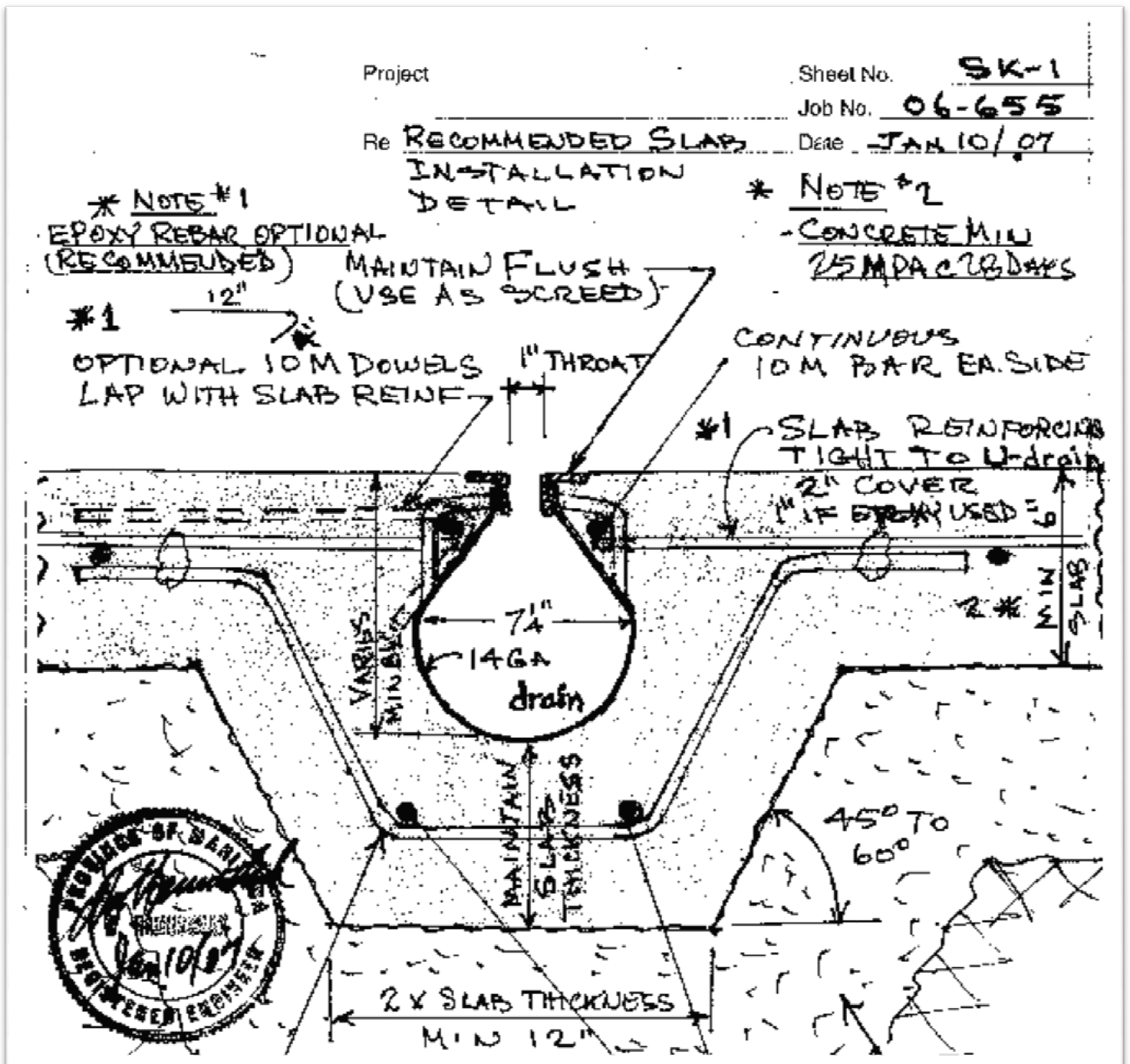

PO Box 119 RR1 • Morris, Manitoba R0G 1K0 • Canada

Toll Free: (855) 746-8200 • Phone: (204) 746-8200

Fax: (204) 746-8074

e-mail: info@norstarindustries.ca

<http://www.norstarindustries.ca>